

1 ORDINANCE NO. 2008-42

AUGUST 12, 2008

2
3 ORDINANCE BY THE RACINE COUNTY ECONOMIC DEVELOPMENT & LAND USE
4 PLANNING COMMITTEE TO REZONE FROM M-2 GENERAL INDUSTRIAL DISTRICT
5 TO M-3 HEAVY INDUSTRIAL DISTRICT

6
7 SECTION 12, T4N, R20E, TOWN OF NORWAY

8
9 APPLICANT: MARC STAEGE

10
11 AN ORDINANCE TO AMEND that Certain Ordinance Entitled RACINE COUNTY
12 ZONING ORDINANCE adopted December 2, 1969, found on pages 185 to
13 232 of the OFFICIAL PROCEEDINGS OF THE RACINE COUNTY BOARD OF
14 SUPERVISORS FOR THE YEAR 1969 as recodified May 28, 1991, by
15 Ordinance 91-196.

16
17 The County Board of Supervisors of the County of Racine ordains as
18 follows: Amend the Racine County Zoning Ordinance and change the
19 zoning district for the following described lands from M-2 General
20 Industrial District to M-3 Heavy Industrial District

21
22 A TRACT OF LAND being a part of the Southwest $\frac{1}{4}$ of the
23 Southeast $\frac{1}{4}$ of Section 12, Town 4 North, Range 20 East, in the Town
24 of Norway, County of Racine, State of Wisconsin, bounded and
25 described as follows:

26 COMMENCE at the South $\frac{1}{4}$ corner of said Section;
27 THENCE North $00^{\circ}36'27''$ West for a distance of 1285.39 feet,
28 along the West line of the said $\frac{1}{4}$ Section, to a point;
29 THENCE North $89^{\circ}57'44''$ East for a distance of 776.69 feet, to
30 a point;
31 THENCE South $00^{\circ}25'17''$ West for a distance of 186.95 feet, to
32 a point;
33 THENCE South $84^{\circ}54'24''$ West for a distance of 132.18 feet, to
34 a point;
35 THENCE South $00^{\circ}19'23''$ East for a distance of 1087.78 feet, to
36 a point in the South line of said $\frac{1}{4}$ Section;
37 THENCE North $89^{\circ}56'43''$ West for a distance of 636.16 feet,
38 along said South line, to the point of commencement.
39 RESERVING the southerly 33.00 feet for public road purposes;
40 CONTAINS 19.4608 acres including road reservation.

41
42 *EXCEPTING THEREFROM the following described tracts, which will*
43 *remain M-2:*

44
45 A TRACT OF LAND being a part of the Southwest $\frac{1}{4}$ of the
46 Southeast $\frac{1}{4}$ of Section 12, Town 4 North, Range 20 East, in the Town
47 of Norway, County of Racine, State of Wisconsin, bounded and
48 described as follows:

49 COMMENCE at the South $\frac{1}{4}$ corner of said Section;
50 THENCE South $89^{\circ}56'43''$ East for a distance of 636.16 feet,
51 along the South line of said $\frac{1}{4}$ Section, to a point;
52 THENCE North $00^{\circ}19'23''$ West for a distance of 33.00 feet, to
53 a point on the North line of Six Mile Road and the point of
54 beginning;
55 THENCE North $89^{\circ}56'43''$ West for a distance of 407.38 feet,
56 along said North line, to a point;

4 THENCE North 13°35'50" East for a distance of 102.08 feet, to
5 a point;
6 THENCE North 19°06'04" East for a distance of 45.07 feet, to a
7 point;
8 THENCE North 39°32'34" East for a distance of 41.62 feet, to a
9 point;
10 THENCE North 58°17'38" East for a distance of 93.35 feet, to a
11 point;
12 THENCE North 70°41'19" East for a distance of 47.91 feet, to a
13 point;
14 THENCE North 75°20'05" East for a distance of 44.87 feet, to a
15 point;
16 THENCE North 57°48'00" East for a distance of 41.80 feet, to a
17 point;
18 THENCE North 38°59'08" East for a distance of 41.41 feet, to a
19 point;
20 THENCE North 26°17'56" East for a distance of 93.86 feet, to a
21 point;
22 THENCE North 40°22'29" East for a distance of 89.22 feet, to a
23 point;
24 THENCE North 53°04'15" East for a distance of 13.35 feet, to
25 a point;
26 THENCE South 00°19'23" East for a distance of 465.18 feet, to
27 the point of beginning.
28 CONTAINS 2.41458 acres.

29
30 -and-
31

32 A TRACT OF LAND being a part of the Southwest ¼ of the
33 Southeast ¼ of Section 12, Town 4 North, Range 20 East, in the Town
34 of Norway, County of Racine, State of Wisconsin, bounded and
35 described as follows:
36 COMMENCE at the South ¼ corner of said Section;
37 THENCE North 00°36'27" West for a distance of 645.25 feet,
38 along the West line of the Southeast ¼, to the point of beginning;
39 THENCE North 00°36'27" West for a distance of 640.96 feet, to
40 a point;
41 THENCE North 89°57'44" East for a distance of 404.33 feet, to
42 a point;
43 THENCE South 01°33'27" West for a distance of 201.81 feet, to
44 a point;
45 THENCE South 14°24'01" West for a distance of 154.81 feet, to
46 a point;
47 THENCE South 06°36'53" West for a distance of 217.89 feet, to
48 a point;
49 THENCE South 62°33'34" West for a distance of 72.87 feet, to a
50 point;
51 THENCE South 80°03'15" West for a distance of 228.30 feet, to
52 a point;
53 THENCE South 89°55'01" West for a distance of 38.91 feet, to
54 the point of beginning.
55 CONTAINS 5.22015 acres.
56
57

4 The official Racine County Zoning Map is hereby amended to
5 conform to this ordinance.

6
7 The Racine County Clerk is directed to transmit duplicate copies of
8 this ordinance by registered mail to the Norway Town Clerk within
9 seven (7) days after this ordinance is adopted.

10
11
12 Respectfully submitted,
13 ECONOMIC DEVELOPMENT & LAND USE PLANNING COMMITTEE

14
15
16
17 _____
18 Robert D. Grove, Chair

19
20
21 _____
22 Mark M. Gleason, Vice Chair

23
24
25 _____
26 Daniel F. Sharkozy, Secretary

27
28
29 _____
30 Q. A. Shakoor, II

31
32 _____
33 Thomas Pringle

34
35 _____
36 Kenneth Hall

37
38 _____
39 John A. Wisch

40
41
42 VOTE REQUIRED: MAJORITY

43
44
45 BOARD ACTION:

46
47 1st Reading _____

48
49 Adopted _____

50
51 2nd Reading _____

52 For _____

53 Against _____

54 Absent _____

55
The Certificate of Publication, in compliance with State Statutes,
is available at Racine County Planning.

FISCAL NOTE - NOT APPLICABLE

NOTE: The purpose of this rezoning is to potentially allow
additional industrial-type uses.

NOTE: The Committee recommended approval of this petition as
this rezoning is compatible with surrounding zoning and
uses and the Town of Norway approved the modified
request.

1
2
3
4
5

REZONE FROM
M-2 TO M-3
(18.7 AC)

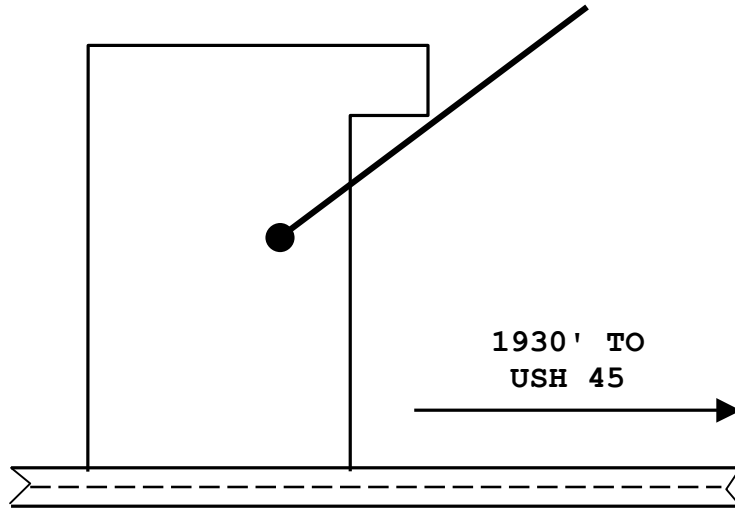

W SIX MILE ROAD

SEC 12 - T4N - R20E
TOWN OF NORWAY